

Substation Indoor Environment Monitoring System based on STM32

Lei Mei*, Sixiao Zhang, Rui Mei, Yulong Shi, Ji Ma

State Grid Jibei Electric Power Co., Ltd., Zhangjiakou Power Supply Company, Zhangjiakou, Hebei, 075000, China

*Corresponding author: Lei Mei, 22126251@bjtu.edu.cn

Copyright: 2026 Author(s). This is an open-access article distributed under the terms of the Creative Commons Attribution License (CC BY-NC 4.0), permitting distribution and reproduction in any medium, provided the original author and source are credited, and explicitly prohibiting its use for commercial purposes.

Abstract: Aiming at the problems of low efficiency of manual monitoring of indoor environment in substation, untimely abnormal response and lack of intelligent control of equipment operation environment, an indoor environment monitoring system of substation based on STM32 single chip microcomputer is designed. The system takes STM32F103C8T6 as the main control core, integrates temperature and humidity, smoke, harmful gas, water leakage detection and other types of sensors, realizes real-time acquisition of environmental parameters, local display, over-limit alarm and remote data transmission functions, and adapts to the strong electromagnetic working environment of substation through anti-interference design. The test results show that the system has stable operation, high data acquisition accuracy and timely alarm response, which can effectively ensure the safe and stable operation of substation indoor equipment and improve the intelligent level of substation environmental management.

Keywords: STM32; Substation; Environmental Monitoring; Sensors

Published: Jun 12, 2026

DOI: <https://doi.org/10.62177/apemr.v3i3.1435>

1. Introduction

As the core hub of power systems, substations' indoor equipment operating environments directly impact grid reliability. Issues such as abnormal temperature/humidity levels, harmful gas leaks, smoke/fire incidents, and water accumulation/leaks can lead to insulation degradation in high-voltage equipment, short circuits, corrosion, or even safety accidents. Traditional manual inspections and scheduled monitoring methods suffer from data delays, missed inspections, and delayed emergency responses, failing to meet smart grid requirements for automated and intelligent substation operations. With rapid advancements in embedded and IoT technologies, microcontroller-based environmental monitoring systems (Li Renpeng, Fu Chuannan & Huang Miao, 2025) have been widely adopted in industrial applications. The STM32 series microcontrollers offer robust processing capabilities, abundant peripheral resources, low power consumption, and excellent interference resistance, making them ideal for complex substation environments. This paper presents an STM32-based indoor environmental monitoring system that enables round-the-clock real-time monitoring of multiple parameters, automatic anomaly alerts, and remote supervision, providing technical support for safe substation operations.

2. System Overall Design

2.1 System Design Requirements

To meet the practical requirements for substation indoor environmental management, the system must fulfill the following

functions:

real-time acquisition of critical environmental parameters such as indoor temperature and humidity, smoke concentration, harmful gases (carbon monoxide, hydrogen sulfide), and water leakage status (Zhang Bo, 2025); local real-time display of monitoring data to visually present the environmental conditions; immediate activation of audible and visual alarms when environmental parameters exceed safety thresholds to alert maintenance personnel; remote wireless transmission of monitoring data supporting real-time viewing and storage on backend computers; and robust electromagnetic compatibility to withstand strong electromagnetic interference in substations, ensuring stable system operation.

2.2 System Architecture

The system adopts the hierarchical architecture design of ‘ front-end acquisition-main control processing-output control-remote transmission ‘. The whole system is divided into six parts: main control module, sensor acquisition module, display module, alarm module, wireless communication module and power module.

Figure 1 The overall structure diagram of the substation indoor environment monitoring system based on STM32

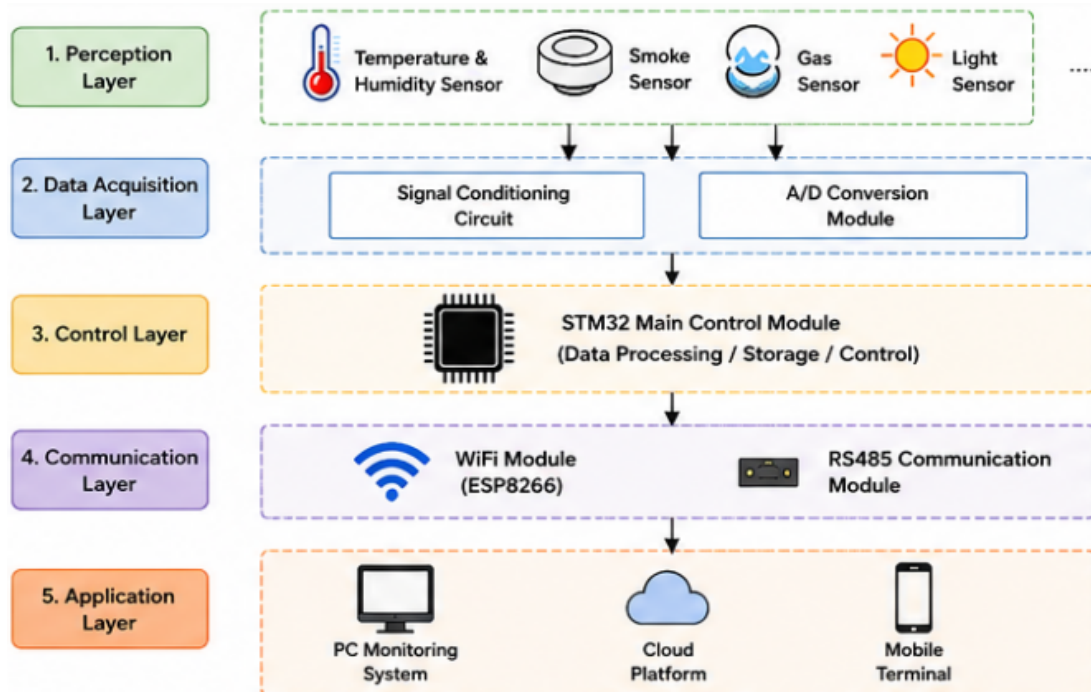

The working process of the system : the sensor acquisition module collects all kinds of environmental parameters in the substation room in real time, and transmits the analog signal / digital signal to the STM32 main control module ; after filtering, analog-digital conversion and data analysis of the signal, the main control unit drives the display module to complete the local display of the data on the one hand, and on the other hand, the monitoring data is compared with the preset threshold. If the data exceeds the limit, the alarm module is started immediately. At the same time, the processed data is uploaded to the remote monitoring platform through the wireless communication module to realize remote real-time monitoring.

3. System Hardware Design

3.1 Master Module

The main control unit employs the STM32F103C8T6 microcontroller, which is based on the ARM Cortex-M3 core (Xu Junjie, Wei Jinghe, Liu Guozhu, He Jian & Zhang Zheng, 2025). With a maximum clock frequency of 72 MHz, it features 128 KB of Flash memory and 20 KB of SRAM, along with comprehensive GPIO interfaces, an ADC analog-to-digital conversion interface, and a serial communication interface, enabling efficient data acquisition, processing, and communication for multiple sensors. Operating within a voltage range of 2.0–3.6 V, the chip offers low power consumption, high stability, and support for various low-power modes, making it ideal for long-term uninterrupted operation in substations.

Figure 2 STM32 minimum system

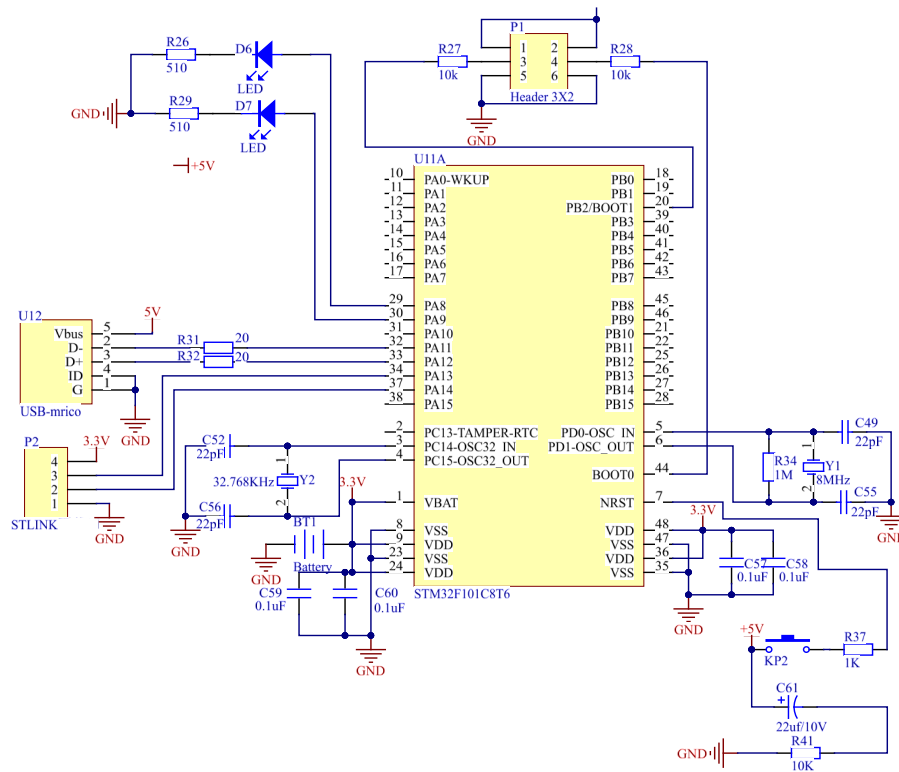

3.2 Sensor Acquisition Module

According to the environmental monitoring requirements of the substation, four types of high-precision sensors are selected to achieve multi-parameter comprehensive acquisition:

Temperature and humidity sensor: DHT11 digital temperature and humidity sensor is selected, and single bus communication protocol is adopted. It can collect 0-50 °C temperature and 20 % -90 % RH humidity data. The accuracy meets the requirements of indoor environment monitoring in substation, and the interface is simple and anti-interference is strong.

Smoke sensor: MQ-2 smoke sensor is selected. Based on semiconductor gas sensor, it can detect smoke and combustible gas concentration in real time. It has fast response speed and high sensitivity, and is suitable for early warning of substation fire.

Harmful gas sensor: MQ-135 gas sensor is selected to detect toxic and harmful gases such as carbon monoxide and hydrogen sulfide, so as to avoid safety risks caused by equipment failure and gas leakage.

Leakage sensor: The contact type leakage sensor is used to detect the water accumulation on the ground and the leakage state of the pipeline in the substation, and the switch signal is output to prevent the water from damaging the power equipment.

Figure 3 System hardware connection schematic diagram

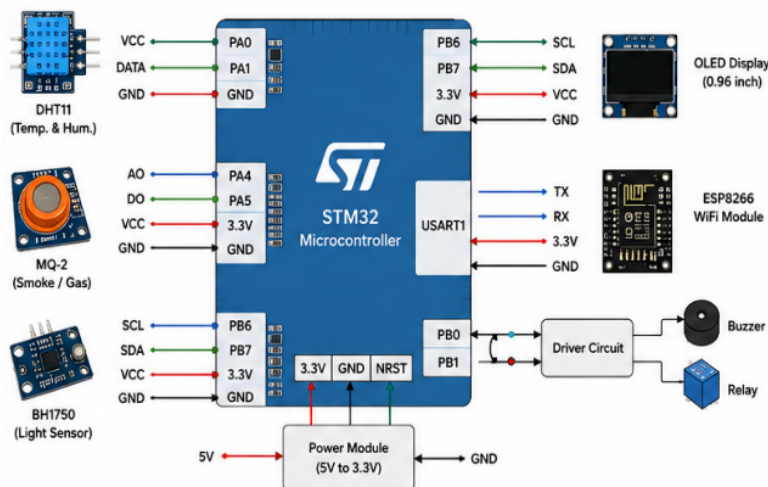

In the design of sensor circuit, signal filtering and photoelectric isolation circuit are added to weaken the influence of strong electromagnetic interference on the acquisition signal and ensure the accuracy of data acquisition.

3.3 Display and Alarm Module

Display module: The 0.96-inch OLED display screen is connected to the STM32 through the I2 C interface. It has the advantages of low power consumption, clear display, fast response, and large visual angle. It can display real-time monitoring data such as temperature and humidity, gas concentration, and water leakage status, which is convenient for on-site operation and maintenance personnel to view. The alarm module is composed of buzzer and LED warning light, which is connected with the main control through GPIO interface. When the monitoring data exceeds the preset safety threshold, STM32 outputs the control signal to drive the buzzer to shout and the LED lamp to flicker, so as to realize the sound and light double alarm and improve the abnormal reminding effect.

3.4 Wireless Communication Module

The NRF24L01 module (Guo Jingbo, Zhang Chao, Zhao Weixing, Zhang Haidong & Zhou Qingxiang, 2018) was selected for remote data transmission. This module supports serial port transparent transmission mode, enabling rapid LAN integration to upload STM32-processed environmental monitoring data to the remote monitoring platform while receiving threshold adjustment and device control commands from the platform, achieving bidirectional communication. With its compact size, stable transmission performance, and low cost, the module meets the wireless data transmission requirements for substation interiors.

Figure 4 Wireless communication schematic diagram

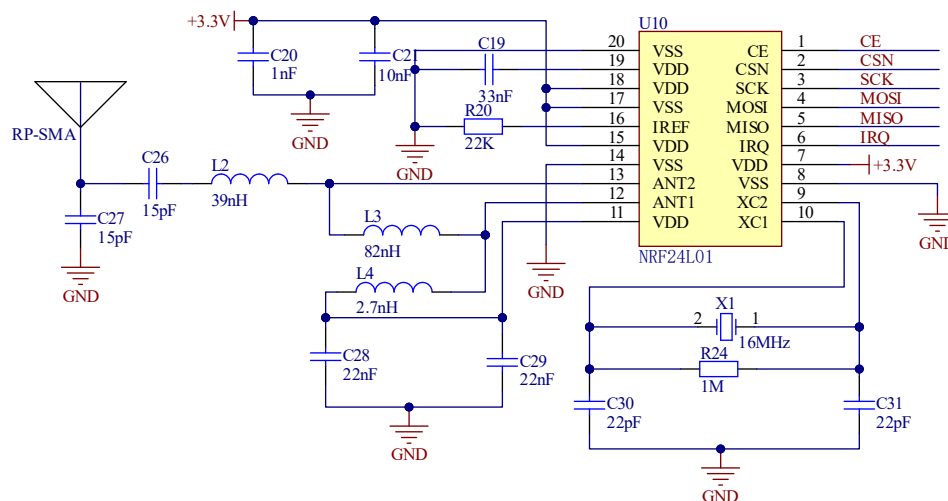

3.5 Power Module

It is powered by 12 V DC power supply, which is converted to 5 V and 3.3 V stable voltage by step-down circuit, which is powered by sensor, WiFi module and STM32 main control unit respectively. The voltage regulator chip, filter capacitor and anti-reverse protection circuit are added to the circuit to improve the stability of the power supply, avoid the influence of voltage fluctuation on the operation of the system, and adapt to the on-site power supply environment of the substation.

Figure 5 Power supply circuit

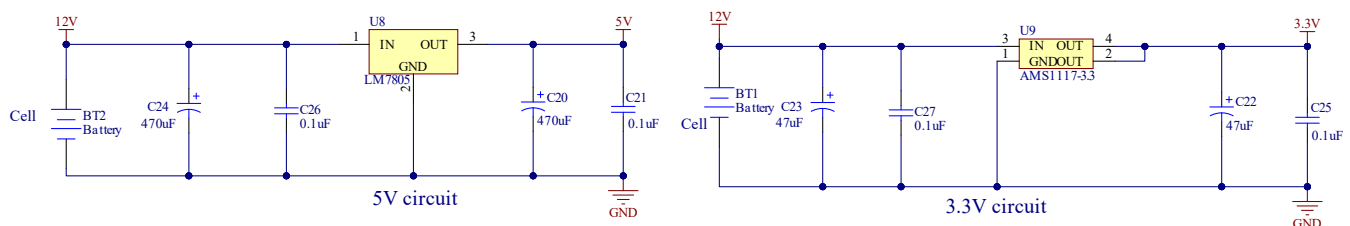

3.6 Electromagnetic Compatibility Design

In view of the strong electromagnetic interference environment of the substation, multiple anti-interference measures are

adopted in the hardware design : the main control circuit and the sensor acquisition circuit are separately wired to reduce signal crosstalk ; magnetic beads and capacitive filtering are added to the communication line ; the key circuit is protected by shielding cover ; the power interface is connected to the transient voltage suppression diode to prevent the surge voltage from damaging the device and ensure the stable operation of the system in the complex electromagnetic environment.

4. System Software Design

The system software is based on the Keil MDK development environment, using C language programming, following the modular design idea, to achieve data acquisition, processing, display, alarm, communication and other functions. The main program flow is: system power-on initialization → sensor data acquisition → data filtering processing → local display → threshold comparison judgment → normal display / overrun alarm → data remote transmission → loop execution.

4.1 Main Program Design

After the system is powered on, the initial configuration of STM32 system clock, GPIO interface, ADC, serial port, OLED display and WiFi module is completed. Then enter the main cycle, regularly start the sensor data acquisition, read the sensor output signal through the interrupt mode, perform mean filtering and error correction processing on the collected original data, and improve the data accuracy; the processed data is pushed to the OLED display screen, and compared with the preset temperature, humidity and gas concentration threshold. If the threshold is exceeded, the alarm will be triggered. Finally, the data is packaged and uploaded to the remote platform through the WiFi module, and the cycle is executed after the completion of a round of monitoring process.

Figure 6 System software flow chart

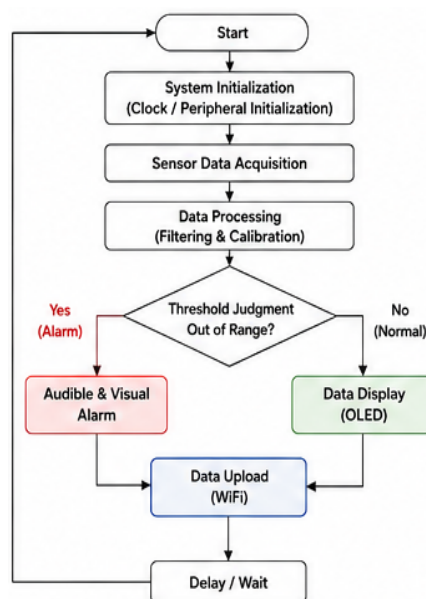

4.2 Data Acquisition Subroutine

For the communication protocols used by different sensors, it is necessary to write corresponding exclusive data acquisition subroutines to ensure the accuracy and real-time performance of data reading. Specifically : DHT11 temperature and humidity sensor based on single bus communication protocol, the subroutine through strict timing control (such as reset signal and response detection, accurate delay with high and low level switching) to complete the data bit by bit read, finally resolve the temperature and humidity value ; for gas sensors such as MQ-2 and MQ-135, the output of the two is positively correlated with the concentration of the analog voltage signal. The subroutine needs to configure the built-in ADC module of STM32 (including channel selection, sampling time setting and resolution calibration). After converting the analog quantity into digital quantity, the corresponding gas concentration value is calculated according to the calibration curve or fitting formula. The leakage sensor uses digital level signal to judge the leakage state, and the subroutine continuously polls or reads the level of the specified IO port in real time through external interruption. Once the effective level jump is detected (such as high and low indicating leakage), the corresponding processing logic (such as setting alarm sign, closing water valve or sending alarm

message) is triggered immediately, so as to realize the rapid response and disposal of abnormal leakage.

4.3 Alarm and Communication Subroutine

The alarm subroutine adopts the interrupt trigger mode, which aims to realize the rapid response to abnormal situations and maximize the safety and reliability of the monitoring system. When any monitoring data (such as temperature and humidity, gas concentration or water leakage state) exceeds the preset safety threshold, the corresponding sensor acquisition subroutine will immediately trigger a hardware or software interrupt, thereby interrupting the current main program. Performing routine tasks (such as data storage, interface refresh, etc.), preferentially jump to the alarm service function. In this function, the system first controls the active buzzer through the GPIO port to continuously output high-frequency sounds, and at the same time drives the high-brightness LED lamp to flash at a specific frequency to form a significant sound and light warning signal to remind the on-site operation and maintenance personnel to dispose of it in time. If the exception persists, the alarm signal will remain active and will not be allowed to be overwritten by the main program or other low-priority tasks. Only when one of the following two exit conditions is satisfied, the alarm state will be cleared: First, all monitoring indicators are restored to the normal range for several consecutive sampling periods, and the system automatically determines that the fault is eliminated, and then the sound and light output is turned off and the main program cycle is restored. Secondly, the operation and maintenance personnel perform manual reset at the scene through buttons or remote instructions, forcing the termination of the current alarm and re-entering the monitoring state. The dual clearing mechanism not only supports automatic operation, but also retains the flexibility of manual intervention, effectively avoiding the long-term failure of the alarm due to signal jitter or residual error.

The communication subroutine is developed using the AT command set of the ESP8266 WiFi module (Zhou Yuanyuan, Sun Zhen & Wang Xuhong, 2026), serving as the core component responsible for reliably transmitting monitoring data to the remote platform and parsing and executing 下行 commands. The subroutine first sends a series of initialization commands to the ESP8266 via the serial port, including setting the operating mode to Station (or AP + Station mode), configuring the target access point's SSID and password, enabling multi-connection or single-connection mode, and establishing a TCP or MQTT connection with the remote server. Once the communication link is established, the subroutine packages the collected data—including temperature, humidity, gas concentration, and water leakage status—according to predefined communication protocols (e.g., JSON format, Modbus-TCP, or custom frame structures). These data frames are then transmitted to the ESP8266 via the serial port using either direct transmission mode or sequential command encapsulation, and forwarded to the cloud platform. To ensure transmission reliability, the subroutine incorporates mechanisms such as timeout retry, automatic reconnection upon connection loss, and data buffer retransmission, maintaining data integrity even under wired or network fluctuations. Meanwhile, the subroutine continuously monitors the ESP8266's serial port data through polling or interrupts. Upon receiving control commands from the platform (e.g., “trigger alarm,” “reset sensor,” or “adjust sampling frequency”), it immediately decodes the command code and activates the corresponding functional module to execute the required operation, enabling bidirectional closed-loop control between the monitoring node and the remote platform.

4.4 Filtering Algorithm Design

In order to eliminate the random error and instantaneous disturbance of the data caused by the complex electromagnetic environment, the noise of the sensor itself and the fluctuation of the ambient temperature and humidity in the industrial field, the system uses the sliding mean filtering algorithm to digitally filter the original collected data to improve the stability and reliability of the monitoring data. Specifically, the algorithm maintains a fixed-length FIFO data queue for each sensor channel (e.g., a queue length of 10 or 20, depending on the sampling frequency and interference characteristics). Each time, the newly collected data is pushed into the tail of the queue, and the old data of the head of the queue is moved out of the queue. Then, all the data samples in the current queue are preprocessed—firstly, the maximum and minimum values are sorted according to the value size, and the maximum and minimum values are eliminated (to eliminate the occasional pulse interference or spike noise), and then the remaining intermediate samples are arithmetically averaged. The calculation results are used as the effective data after this filtering for subsequent concentration conversion, over-limit judgment and upload processing. This sliding window filtering mechanism can not only effectively suppress high-frequency random interference

and periodic noise, but also track the output faster than the ordinary average filtering when the real value of the input signal changes step by step, avoiding excessive delay and signal lag. Compared with simple clipping filtering or median filtering, sliding mean filtering achieves a good balance between smoothness and real-time performance, which significantly improves the repeatability and long-term stability of the data collected by the system under complex working conditions, and provides more reliable raw data support for subsequent over-limit alarm, trend analysis and remote monitoring.

5. System Test and Result Analysis

In order to verify the performance of the system, the indoor simulation test environment of the substation is built, and the system function, data accuracy, stability and alarm response are comprehensively tested. The ambient temperature is 25 °C and the humidity is 45 % RH, and the conventional working state of the substation is simulated.

5.1 Functional Test

After the system is powered on and the initialization is completed, the OLED display immediately refreshes the current environmental monitoring data in real time with a clear font and a reasonable layout, including the temperature and humidity values collected by DHT11, the gas concentration estimation values output by MQ-2 and MQ-135, and the status information of the water leakage sensor. The display screen is stable without flicker, and the data update cycle is consistent with the acquisition frequency, which directly reflects the normal operation state of the system. In order to further verify the response ability of the system under different environmental conditions, a number of simulation tests were carried out in turn. By changing the temperature and humidity conditions of the local environment through the heater and the humidifier, the system can quickly identify the numerical changes after data acquisition and dynamically update on the OLED. The lighter is used to release a small amount of butane gas to simulate the smoke leakage scene. The gas concentration curve rises obviously, and the system immediately perceives the over-threshold trend. Drop a small amount of water into the water leakage sensor probe, and its output level jumps. At the moment of the above-mentioned abnormal triggering, the system can accurately determine the over-standard or water leakage state, and start the sound and light alarm-buzzer to issue a high-frequency warning sound under the drive of the alarm subroutine of the interrupt priority within 1 second. The LED warning light flashes synchronously, and the response is timely and the action is clear. At the same time, the WiFi communication module based on ESP8266 automatically accesses the preset wireless routing network after power on, and maintains a long connection state. There is no disconnection or authentication failure during the test. All filtered monitoring data are packaged in a custom JSON format, and are transmitted to the WiFi module through the serial port and stably pushed to the remote monitoring platform. By comparing the platform receiving records with the local data one by one, it is verified that the data transmission has no packet loss and no disorder, and the end-to-end delay is controlled at the millisecond level to meet the real-time monitoring requirements. In summary, the data acquisition, anomaly detection, alarm linkage and wireless communication of the system work stably and reliably, and all functional indicators meet the project design requirements.

Figure 7 System communication and data transmission structure diagram

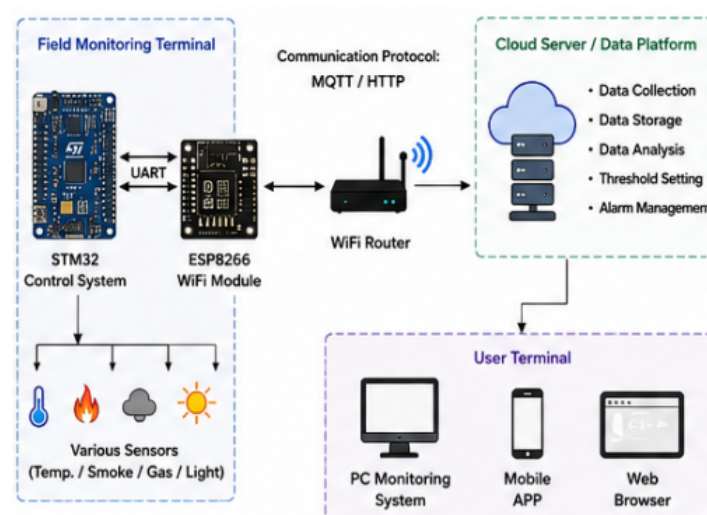

5.2 Data Accuracy Test

In order to ensure the accuracy and reliability of the monitoring data of the system, the standard temperature and humidity meter (accuracy of ± 0.1 °C, ± 1 % RH) and the standard gas detector are used as the reference equipment, and the data collected by the system are compared and tested synchronously under the same environmental conditions. During the test, several typical operating points (such as low temperature and low humidity, normal temperature and normal humidity, high temperature and high humidity, and different gas concentration scenarios) were selected for long-term continuous comparison records. The experimental results show that the maximum absolute error between the temperature data measured by the system and the standard temperature and humidity meter does not exceed ± 0.5 °C, the humidity error is controlled within ± 3 % RH, and the relative error of gas concentration detection does not exceed ± 5 %. The above error indexes are better than the allowable error requirements proposed in the relevant technical specifications of substation indoor environment monitoring (usually temperature error $\leq \pm 1$ °C, humidity error $\leq \pm 5$ % RH, gas concentration error $\leq \pm 10$ %). The achievement of this accuracy level benefits from the effective application of high-precision sensor selection, optimized signal conditioning circuit design and sliding mean filtering algorithm, which effectively suppresses the influence of electromagnetic interference and random noise on the sampling results. Therefore, the data of temperature, humidity and gas concentration collected and reported by the system have good accuracy, repeatability and long-term stability, which can be used as a reliable basis for substation environmental safety assessment, early warning of equipment operating conditions and remote operation and maintenance decision-making.

Figure 8 Environmental parameter monitoring and alarm mechanism diagram

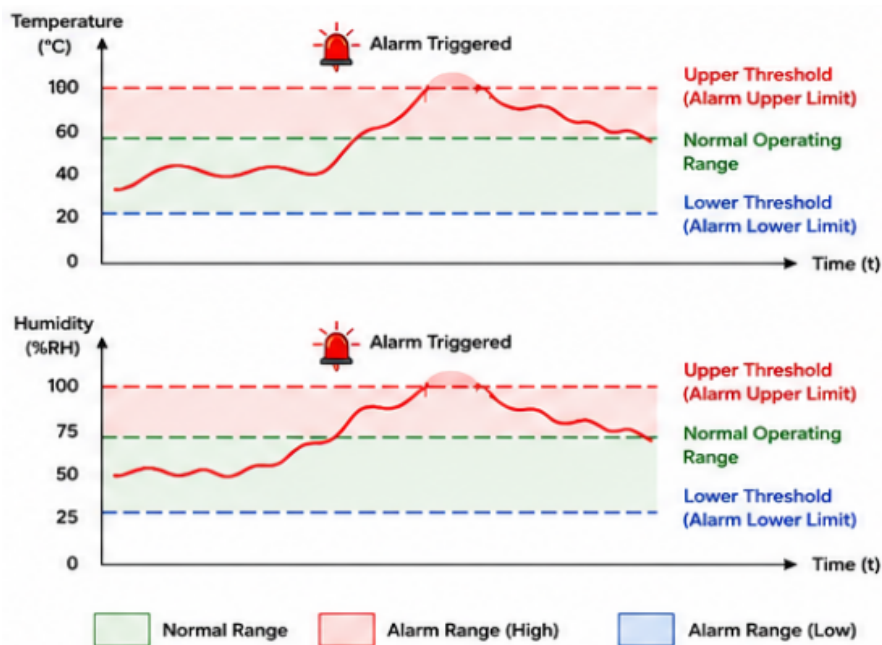

5.3 Stability and Anti-Interference Test

Under the strong electromagnetic interference environment of the simulated substation, the system runs continuously for 72 hours without problems such as crash, data disorder, and communication interruption. The monitoring data fluctuation is small, the alarm function triggers accurately, and the electromagnetic compatibility design effect is remarkable. It can adapt to the complex industrial environment of the substation and has good long-term operation stability.

6. Conclusion and Foresight

The substation indoor environment monitoring system based on STM32 designed in this paper takes STM32F103C8T6 as the core, integrates multi-type sensors and wireless communication technology, and realizes the functions of all-weather real-time monitoring, local display, over-limit alarm and remote monitoring of substation indoor multi-environment parameters. The hardware structure of the system is simple, the cost is low, the anti-interference is strong, and the software design is modular and easy to maintain. The test results show that the system runs stably, the data is accurate, and the response is

timely. It can effectively solve the disadvantages of traditional substation environmental monitoring, improve the intelligent level of substation environmental management, and ensure the safe operation of power equipment. The follow-up research can further optimize the system function : add more environmental parameter monitoring modules and expand the monitoring dimension ; integrate into the Internet of Things cloud platform to realize data cloud storage, historical query, and abnormal report generation ; combined with mobile communication technology, the remote early warning push of mobile phone APP is realized, which further improves the convenience and practicability of the system and promotes the construction and development of intelligent substation.

Funding

No

Conflict of Interests

The authors declare that there is no conflict of interest regarding the publication of this paper.

Reference

- [1] Li Renpeng, Fu Chuannan & Huang Miao. (2025). Design of substation environment monitoring system based on Internet of Things. *Mechanical Engineering & Automation*, 54(05), 197-200.
- [2] Zhang Bo. (2025). Automatic environmental monitoring method for 220kV substation infrastructure site under 5G network architecture. *Microcomputer Applications*, 41(07), 252-255.
- [3] Xu Junjie, Wei Jinghe, Liu Guozhu, He Jian & Zhang Zheng. (2025). Design and Implementation of a PCIe RP System Based on the Cortex-M3 Core. *Integrated Circuits and Embedded Systems*, 25(08):74–80. <https://doi.org/10.20193/j.ices2097-4191.2025.0051>.
- [4] Guo Jingbo, Zhang Chao, Zhao Weixing, Zhang Haidong & Zhou Qingxiang. (2018). Design of a fire pump inspection and monitoring system based on the nRF24L01 wireless module. *Fire Science and Technology*, 37(09),1228–1231.
- [5] Zhou Yuanyuan, Sun Zhen & Wang Xuhong. (2026). Design of a Smart Home System Based on Cloud-Edge-Device Collaboration—With ESP32/ESP8266 as the Core. *Internet of Things Technology*, 16(09),65–69. <https://doi.org/10.16667/j.issn.2095-1302.2026.09.015>.